

Technical specification sheet

Gas/Petrol Duo Pump | SR 20 PC 2

Specifications		
article number		150.152.696
model		SR 20 PC 2
equipped with (connector type)		CORE
short description		Gas/Petrol Duo Pump
max. working pressure	bar/Mpa	720 / 72
number of stages		3
first stage pressure range	bar/Mpa	0 - 150 / 0 - 15
first stage output / min.	cc	2900
second stage pressure range	bar/Mpa	150 - 280 / 15 - 28
second stage output / min.	cc	1300
third stage pressure range	bar/Mpa	280 - 720 / 28 - 72
third stage output / min.	cc	550
capacity fuel tank	cc	1700
continuous operation	hrs	3.5
sound emission (acc. to EN 13204)	dB(A)	85
sound emission (unloaded)	dB(A)	81
capacity oil tank	cc	4340
capacity oil tank (effective)	cc	4000
operator type		petrol engine
number of tool connections		2
number of tools simultaneously usable		2
pump type		2 x 3-stage axial pump
engine		4-stroke - 3.0 HP - 2.2 kW
weight, ready for use	kg	22.7
dimensions (LxWxH)	mm	455 x 315 x 460
temperature range	°C	-20 + 55

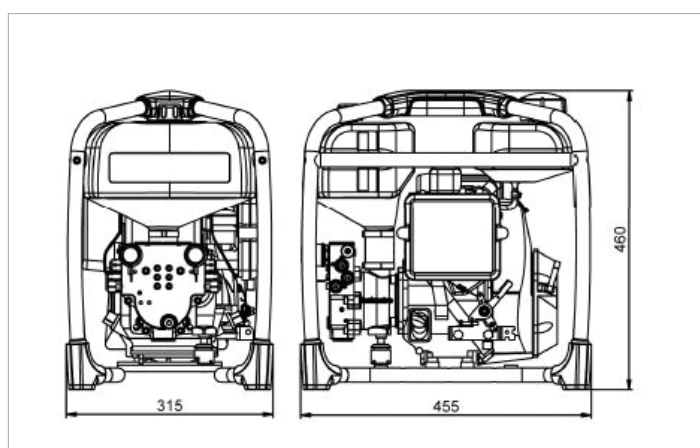

Norms	Tested	Classification
EN 13204	✓	MTO
NFPA 1936	✓	

Standard supplied with
<ul style="list-style-type: none"> Hydraulic oil level indicator Soft-grip carrying handle

Accessories	
CORE Elbow Connector	150.182.176
Quick Fix And Release Bracket	150.062.188
LED Light Spider Range	590.000.343
Mounting Plate Pump Side SR 20	150.062.190
Angled Mounting Plate Truck Side	150.062.193