

Thyristor Modules

Thyristor/Diode Modules

$$I_{TRMS} = 2 \times 180 \text{ A}$$

$$I_{TAVM} = 2 \times 116 \text{ A}$$

$$V_{RRM} = 800-1800 \text{ V}$$

V_{RSM}	V_{RRM}	Type	
V_{DSM}	V_{DRM}	Version	1 B 8 B
V	V	Version	1 B 8 B
900	800	MCC 95-08	io1 B / io8 B
1300	1200	MCC 95-12	io1 B / io8 B
1500	1400	MCC 95-14	io1 B / io8 B
1700	1600	MCC 95-16	io1 B / io8 B
1900	1800	MCC 95-18	io1 B / io8 B
		MCD 95-08	io1 B / io8 B
		MCD 95-12	io1 B / io8 B
		MCD 95-14	io1 B / io8 B
		MCD 95-16	io1 B / io8 B
		MCD 95-18	io1 B / io8 B

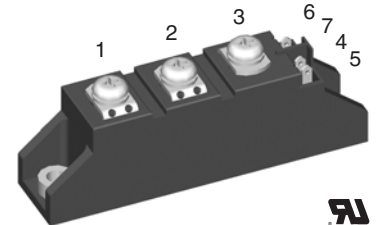
TO-240 AA

Symbol	Conditions	Maximum Ratings	
I_{TRMS}, I_{FRMS}	$T_{VJ} = T_{VJM}$	180	A
I_{TAVM}, I_{FAVM}	$T_C = 85^\circ\text{C}; 180^\circ \text{ sine}$	116	A
I_{TSM}, I_{FSM}	$T_{VJ} = 45^\circ\text{C}$	$t = 10 \text{ ms (50 Hz), sine}$	2250 A
	$V_R = 0$	$t = 8.3 \text{ ms (60 Hz), sine}$	2400 A
$\int i^2 dt$	$T_{VJ} = 45^\circ\text{C}$	$t = 10 \text{ ms (50 Hz), sine}$	25 300 A^2s
	$V_R = 0$	$t = 8.3 \text{ ms (60 Hz), sine}$	23 900 A^2s
$(di/dt)_{cr}$	$T_{VJ} = T_{VJM};$ $f = 50 \text{ Hz}; t_p = 200 \mu\text{s}$ $V_D = \frac{2}{3} V_{DRM};$	repetitive, $I_T = 250 \text{ A}$	150 $\text{A}/\mu\text{s}$
	$I_G = 0.45 \text{ A};$ $di_G/dt = 0.45 \text{ A}/\mu\text{s}$	non repetitive, $I_T = I_{TAVM}$	500 $\text{A}/\mu\text{s}$
$(dv/dt)_{cr}$	$T_{VJ} = T_{VJM};$ $R_{GK} = \infty; \text{method 1 (linear voltage rise)}$	$V_{DR} = \frac{2}{3} V_{DRM}$	1000 $\text{V}/\mu\text{s}$
P_{GM}	$T_{VJ} = T_{VJM};$	$t_p = 30 \mu\text{s}$	10 W
	$I_T = I_{TAVM};$	$t_p = 300 \mu\text{s}$	5 W
P_{GAV}			0.5 W
V_{RGM}			10 V
T_{VJ}			-40...+125 $^\circ\text{C}$
T_{VJM}			125 $^\circ\text{C}$
T_{stg}			-40...+125 $^\circ\text{C}$
V_{ISOL}	50/60 Hz, RMS;	$t = 1 \text{ min}$	3000 V~
	$I_{ISOL} \leq 1 \text{ mA};$	$t = 1 \text{ s}$	3600 V~
M_d	Mounting torque (M5)		2.5-4.0/22-35 Nm/lb.in.
	Terminal connection torque (M5)		2.5-4.0/22-35 Nm/lb.in.
Weight	Typical including screws		90 g

Data according to IEC 60747 and refer to a single thyristor/diode unless otherwise stated.

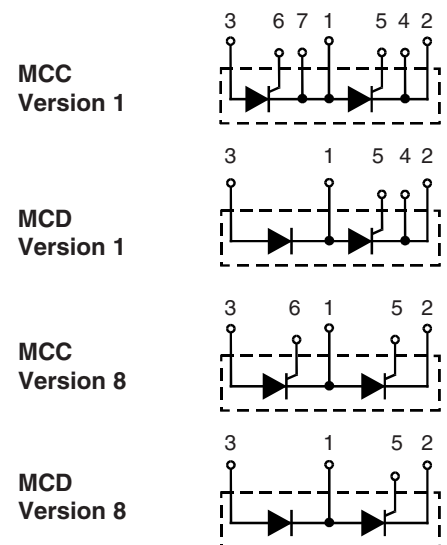
Features

- International standard package, JEDEC TO-240 AA
- Direct copper bonded Al_2O_3 -ceramic base plate
- Planar passivated chips
- Isolation voltage 3600 V~
- UL registered, E72873
- Gate-cathode twin pins for version 1

Applications

- DC motor control
- Softstart AC motor controller
- Light, heat and temperature control

Advantages

- Space and weight savings
- Simple mounting with two screws
- Improved temperature and power cycling
- Reduced protection circuits

Symbol	Conditions	Characteristic Values
I_{RRM}, I_{DRM}	$T_{VJ} = T_{VJM}; V_R = V_{RRM}; V_D = V_{DRM}$	5 mA
V_T, V_F	$I_T/I_F = 300 \text{ A}; T_{VJ} = 25^\circ\text{C}$	1.5 V
V_{T0}	For power-loss calculations only ($T_{VJ} = 125^\circ\text{C}$)	0.8 V
r_T		2.4 mΩ
V_{GT}	$V_D = 6 \text{ V}; T_{VJ} = 25^\circ\text{C}$	2.5 V
	$T_{VJ} = -40^\circ\text{C}$	2.6 V
I_{GT}	$V_D = 6 \text{ V}; T_{VJ} = 25^\circ\text{C}$	150 mA
	$T_{VJ} = -40^\circ\text{C}$	200 mA
V_{GD}	$T_{VJ} = T_{VJM}; V_D = \frac{2}{3} V_{DRM}$	0.2 V
I_{GD}		10 mA
I_L	$T_{VJ} = 25^\circ\text{C}; t_p = 10 \mu\text{s}; V_D = 6 \text{ V}$ $I_G = 0.45 \text{ A}; di_G/dt = 0.45 \text{ A}/\mu\text{s}$	450 mA
I_H	$T_{VJ} = 25^\circ\text{C}; V_D = 6 \text{ V}; R_{GK} = \infty$	200 mA
t_{gd}	$T_{VJ} = 25^\circ\text{C}; V_D = \frac{1}{2} V_{DRM}$ $I_G = 0.45 \text{ A}; di_G/dt = 0.45 \text{ A}/\mu\text{s}$	2 μs
t_q	$T_{VJ} = T_{VJM}; I_T = 150 \text{ A}, t_p = 200 \mu\text{s}; -di/dt = 10 \text{ A}/\mu\text{s}$ $V_R = 100 \text{ V}; dv/dt = 20 \text{ V}/\mu\text{s}; V_D = \frac{2}{3} V_{DRM}$	typ. 185 μs
Q_S	$T_{VJ} = T_{VJM}; I_T/I_F = 50 \text{ A}, -di/dt = 6 \text{ A}/\mu\text{s}$	170 μC
I_{RM}		45 A
R_{thJC}	per thyristor/diode; DC current per module	0.22 K/W
R_{thJK}	per thyristor/diode; DC current per module	0.11 K/W 0.42 K/W 0.21 K/W
	other values see Fig. 8/9	
d_s	Creepage distance on surface	12.7 mm
d_A	Strike distance through air	9.6 mm
a	Maximum allowable acceleration	50 m/s ²

Optional accessories for module-type MCC 95 version 1 B

Keyed gate/cathode twin plugs with wire length = 350 mm, gate = yellow, cathode = red
 Type **ZY 200L** (L = Left for pin pair 4/5) } UL 758, style 1385,
 Type **ZY 200R** (R = right for pin pair 6/7) } CSA class 5851, guide 460-1-1

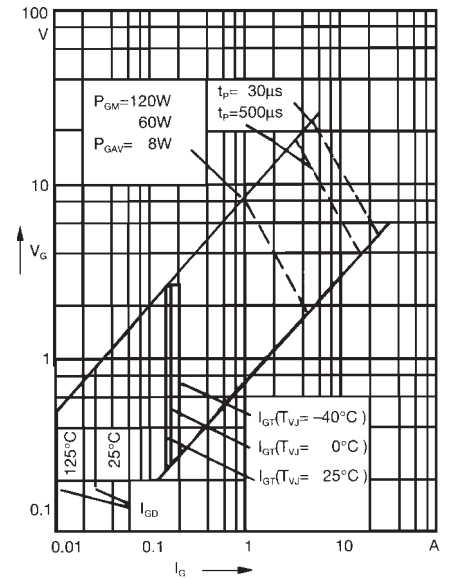

Fig. 1 Gate trigger characteristics

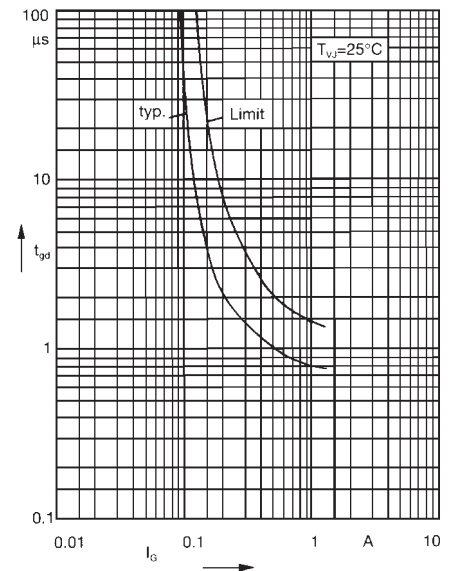
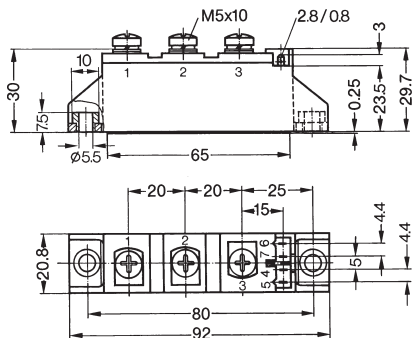

Fig. 2 Gate trigger delay time

Dimensions in mm (1 mm = 0.0394")

MCC / MCD Version 1 B



MCC Version 8 B

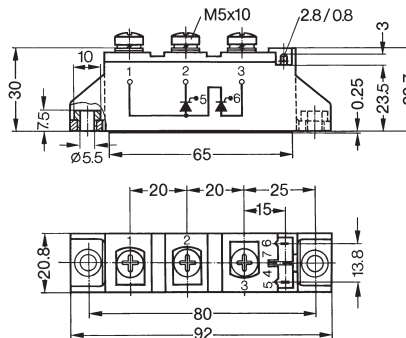

MCD Version 8 B

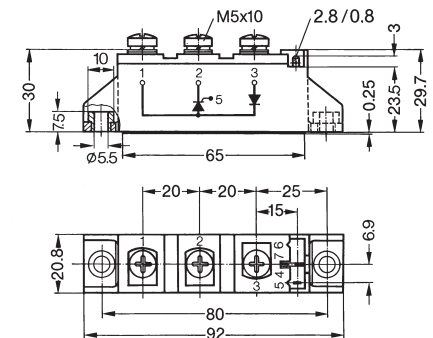

Version 1 or 8 without B in typ designation = without insert in mounting holes

IXYS reserves the right to change limits, test conditions and dimensions.

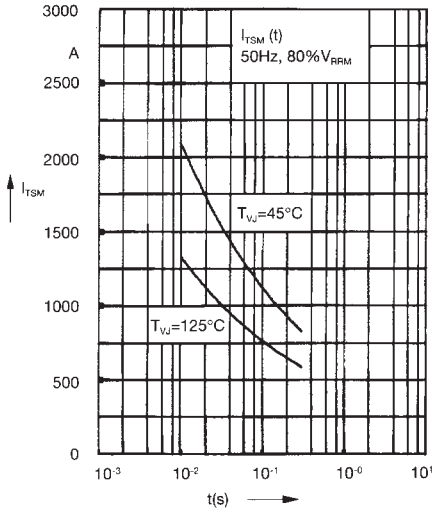

Fig. 3 Surge overload current
 I_{TSM} , I_{FSM} : Crest value, t: duration

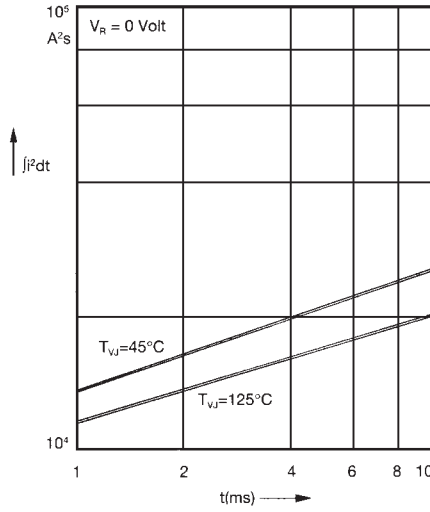

Fig. 4 $\int i^2 dt$ versus time (1-10 ms)

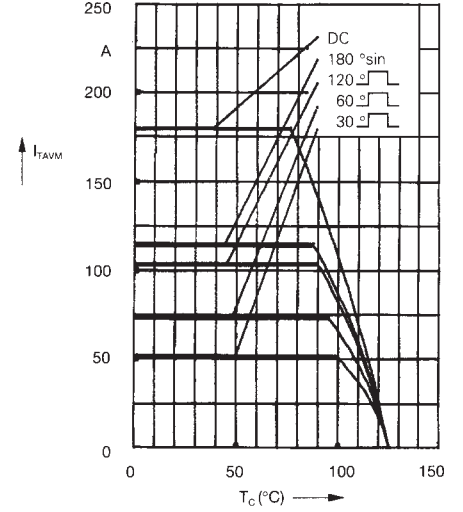

Fig. 4a Maximum forward current at case temperature

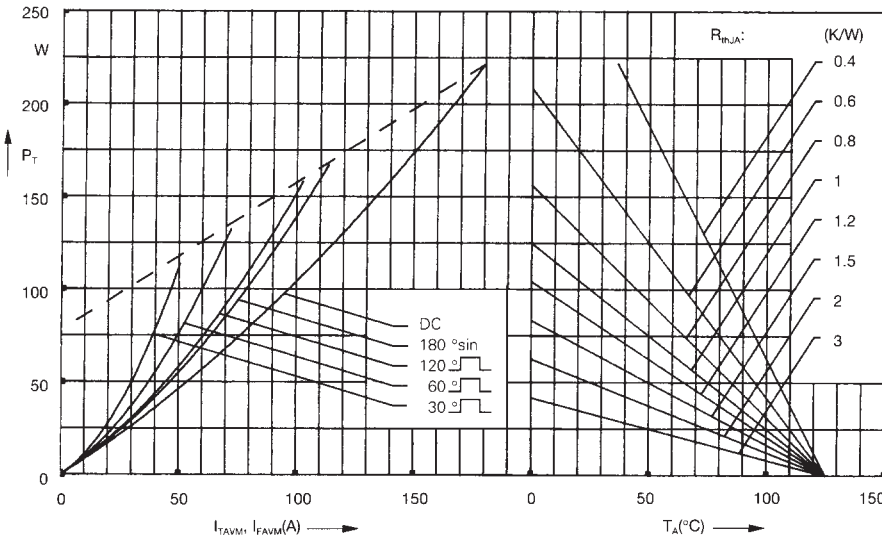

Fig. 5 Power dissipation versus on-state current and ambient temperature (per thyristor or diode)

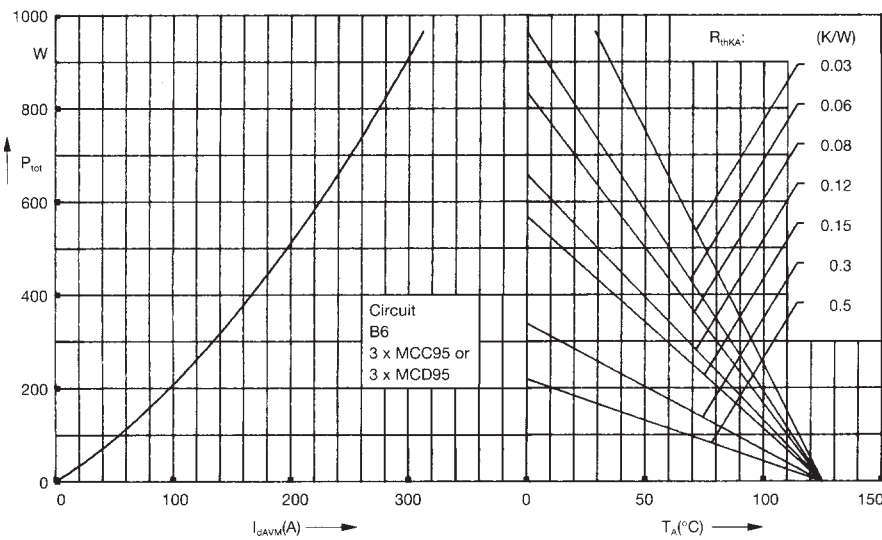

Fig. 6 Three phase rectifier bridge: Power dissipation versus direct output current and ambient temperature

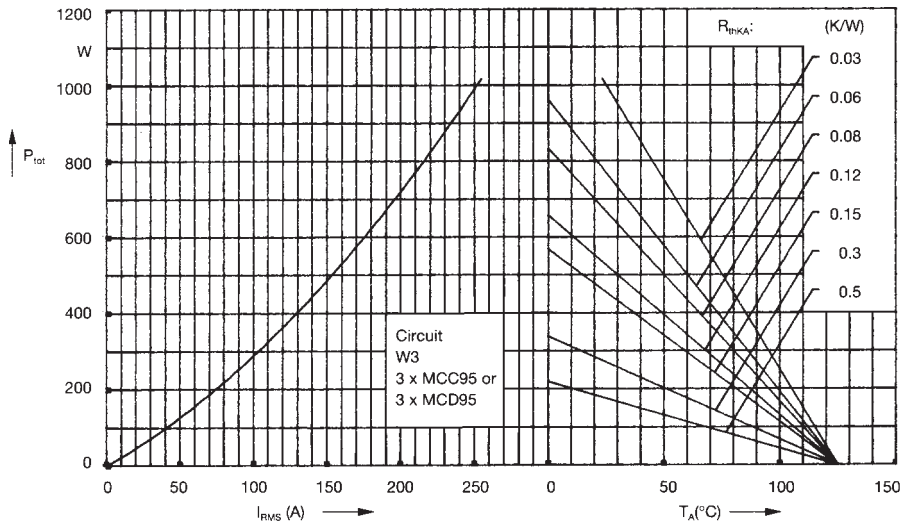

Fig. 7 Three phase AC-controller: Power dissipation versus RMS output current and ambient temperature

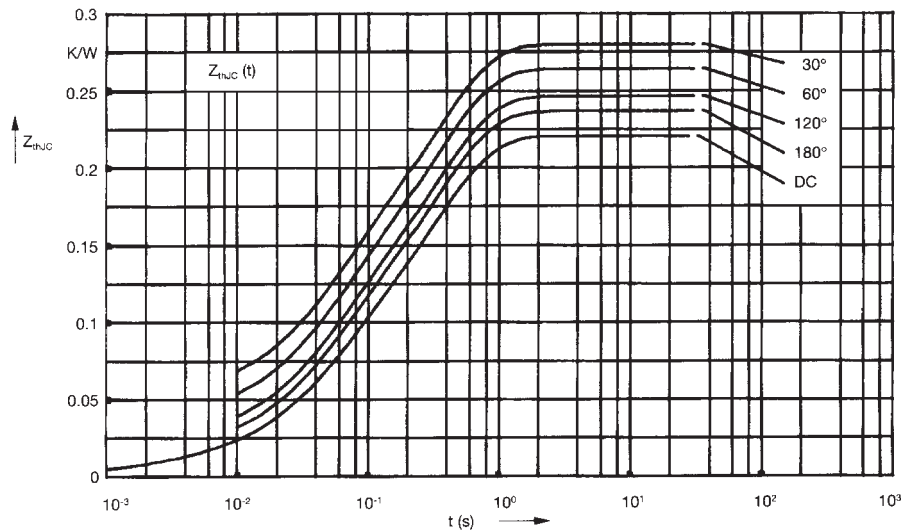

Fig. 8 Transient thermal impedance junction to case (per thyristor or diode)

R_{thJC} for various conduction angles d:

d	R_{thJC} (K/W)
DC	0.22
180°	0.23
120°	0.25
60°	0.27
30°	0.28

Constants for Z_{thJC} calculation:

i	R_{thi} (K/W)	t_i (s)
1	0.0066	0.0019
2	0.0678	0.0477
3	0.1456	0.344

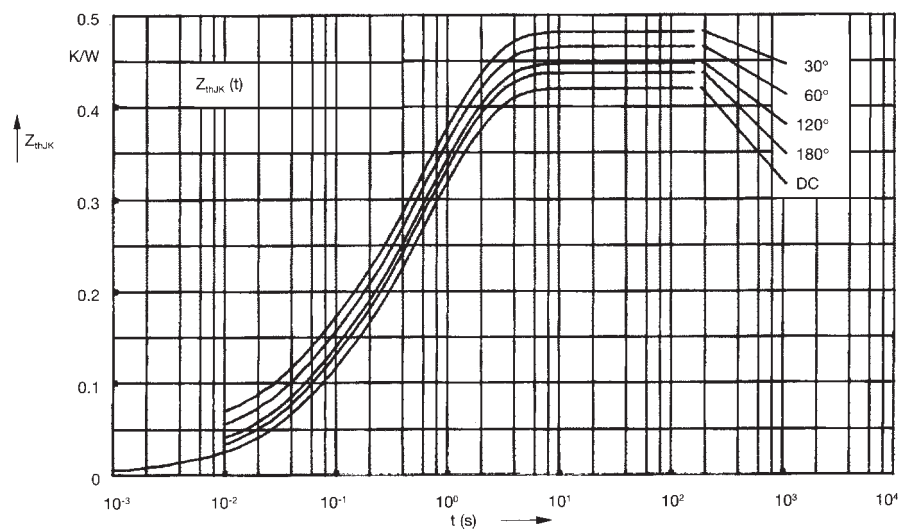

Fig. 9 Transient thermal impedance junction to heatsink (per thyristor or diode)

R_{thJK} for various conduction angles d:

d	R_{thJK} (K/W)
DC	0.42
180°	0.43
120°	0.45
60°	0.47
30°	0.48

Constants for Z_{thJK} calculation:

i	R_{thi} (K/W)	t_i (s)
1	0.0066	0.0019
2	0.0678	0.0477
3	0.1456	0.344
4	0.2	1.32