



- small dimensions
- simple application
- universal usage
- wide selection
- favourable price

The transducers series Z are designed for a general use. They are capable to measure both the positive and negative pressure in the liquids and gases that are not chemically aggressive. The differential transducers are designed just for the non-aggressive gases.

These transducers series Z will find a wide use in a full scale of the industrial automation, power measurements, sanitary technology, agricultural applications. Their availability and small dimensions make them popular for a device design, for laboratory measurements, etc. The transducer case is made from duralumin with the colorless eloxal surface finish. The connecting thread proper has a dimension M12x1.5. This transducer may be ordered with a thread G 1/2" or M20x1.5. This is realized by a fix installation of a special reduction immediately at the manufacturer. This case has a diameter 39 mm and includes all circuits that are necessary for a function of this transducer.

As a pressure sensing element in this series of transducers, there may be used two types of piezoelectric sensors – silicon or ceramic ones. As for the pressure ranges, the silicon diaphragms are determined for the lower pressures and the ceramic ones for the higher pressures, see the engineering data on the second page of this sheet. Unlike the ceramic sensors, diaphragm of the silicon sensors is not galvanically separated from the power supplies, however, it is possible to reach a higher pressure overload capacity. The ceramic membranes are convenient only for the relative and absolute pressure measurement and because of their high chemical resistance, they may be recommended for applications in the heating and water-supply engineering. As for the sensor with a silicon diaphragm, the medium being measured is in a contact with the following materials: duralumin, silicon, Viton, silicone rubber, polyetherimide; for the ceramic diaphragm version, those materials are: duralumin, corundum ceramics, Viton.

The transducer design uses new modern elements, surface mount technology, etc. A special care is taken of the resistance against the outer electromagnetic and electrostatic interference. The case body is not electrically connected with the system but it is connected to the earthing pin of the connector. We recommend to connect always this pin to the fixed potential, especially with a view to achieving satisfactory immunity against the outer electromagnetic interference. Electric connection is realized by means of the sealed arrested connector (ISO 4400/6952 – DIN 43650) with a cable bushing PG9, which enables to connect the transducer by means of the cable with a diameter 6 – 9 mm.

Electric signal from the sensor, which is proportional to the pressure applied, is amplified, filtered, calibrated and transferred to the required output quantity. The pressure transducers series Z are commonly manufactured with the current outputs 4÷20 mA (two-wire) or 0 - 20 mA (three-wire) and the voltage output 0 – 10 V. If agreed, it is possible to set different values, namely for the voltage outputs. The transducers may be supplied by a DC voltage in the range 12 – 36 V. Change of the supply voltage in this range has no actual influence on the measurement accuracy. Calibration of this transducer is performed using the fixed resistors. A possible fine adjustment of the transfer characteristic limit points may be done by two multi-rotation trimmers, which may be used for corrections within 2 % of the nominal range.

Cressto, s. r. o.

Hasičská 2643, 756 61 Rožnov p. R., Czech Republic
 tel.: +420 571 843 162, +420 571 845 338, fax: +420 571 842 616
 e-mail: firma@cressto.cz, www.cressto.cz

TECHNICAL INFORMATION

Nominal pressure range	± 2,5kPa to 6MPa
Overpressure to 40 kPa from 60 kPa to 6MPa	100 kPa 200% nominal range
Error	max. 1% (0.5%)
Zero temperature error	typ. 0,1% max. 0,3%/10°C
Span temperature error	typ. 0,1% max. 0,3%/10°C
Compensated temp. range	0 ÷ +70°C
Operating temp. range	-20 ÷ +85°C (non condensing)
Storage temperature	-25 ÷ 100°C
Supply voltage	12 ÷ 36V dc
Supply current – output H	< 4mA
Output	4 ÷ 20mA two-wire 0 ÷ 20mA three-wire 0 ÷ 10V three-wire 2 ÷ 10V three-wire
Operated position	arbitrary
Voltage strength	min. 1000V dc
Protection	min. IP 54
Weight	cca 100g
Common-mode pressure for differential version	max. 1Mpa

CE EMC – according to ČSN EN 61326-1

At the customer's wish it is possible to secure a metrological verification of the transmitters at an accredited Calibration Service Centre.

INSTRUCTIONS FOR USE

- Before connection of the transducer into the pressure circuit, it is necessary to verify that the pressure being measured corresponds to the nominal range of this transducer. Even a transient loading over the maximum allowable overpressure may cause a destruction of the measuring diaphragm!
- Especially by using silicon membrane is necessary to check up resistnace of materials, see the front of this sheet. In case of doubt contact the manufacturer.
- For sealing the transmitter is recommended to use the "O" ring 12x2 supplied with the transmitter. During sealing into the thread (teflon, tow) for fluid medium is necessary take notice of, because during driving screws into a closed volume of fluid can increase pressure and thereby can be the membrane destroyed!

DIAGRAM

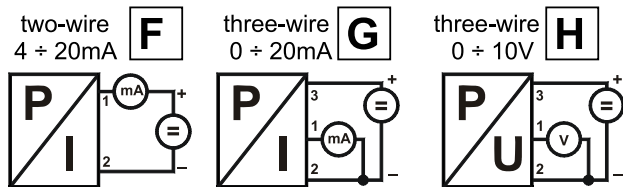

PIN ASSIGNMENTS VALID FOR CONNECTOR DIN 43650

	two-wire 4 ÷ 20mA	three-wire 0 ÷ 20mA	three-wire 0 ÷ 10V
+ supply voltage	1	3	3
- supply voltage	2	2	2
output		1	1
shielding	⊥	⊥	⊥

ORDERING CODE

TM G617Z3F

type of press. measure.		
relative overpressure		
absolute, barometrical	A	
differential	D	
relative underpressure	V	
exponent of pressure range		
10 ³ Pa (units kPa)		3
10 ⁴ Pa (tens kPa)		4
10 ⁵ Pa (hundreds kPa)		5
10 ⁶ Pa (units MPa)		6
multiplicand of pressure range		
1,0		1
1,6		2
2,5		3
4,0		4
6,0		6
membrane material		
ceramic(10kPa – 6MPa)		7
silicon(2,5kPa – 600kPa)		8
case material		
duralumin		Z
electrical connection		
conektor DIN 43650		3
elektrical output		
current 4÷20mA		F
current 0÷20mA		G
voltage 0÷10V		H
voltage 2÷10V		E
pressure connection		
outer thread M12x1,5; duralumin		S
outer thread G1/4"; duralumin		A
outer thread G1/4";nickel plated brass		B
outer thread M12x1,5;nickel plated brass		C
outer thread M20x1,5;nickel plated brass		D
outer thread G1/2";nickel plated brass		
additional signs		

DIMENSIONS

relative version

differential version

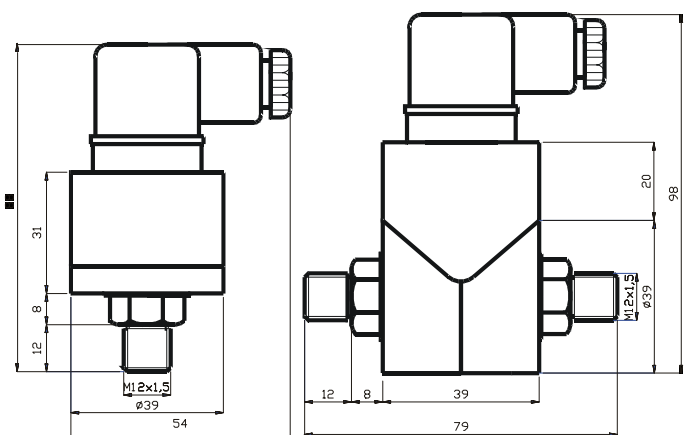

MAINTENANCE

- The device requires no maintenance during operation. Potential reparation performs manufacturer. Device will be electronic waste after end of its usage. The user is obliged to guarantee liquidation of device in accordance with a valid prescription at the liquidation time. It is recommended deliver it to authorised person.